



A2 Series Internal Combustion Forklift

with capacities of 1,500 to 3,800kg



HANGCHA

HANGCHA GROUP CO., LTD.

Factory site: 666 Xiangfu Road,
Hangzhou, Zhejiang, China (311305)

Tel: +86-571-88926735 88926755
Fax: +86-571-88926789 88132890

sales@hcforklift.com
www.hcforklift.com



Follow us on
Facebook



Follow us on
YouTube



Follow us on
WeChat



Download "Hangcha
Forklift" App



ISO45001
ISO45001:2018



ISO14001
ISO14001:2015



ISO9001
ISO9001:2015



HANGCHA trucks conform
to the European Safety
Requirements.

2024 VERSION 5/COPYRIGHT 2024/10

HANGCHA GROUP CO., LTD. reserves the right to make any changes without notice concerning colors, equipment, or specifications detailed in this brochure, or to discontinue individual models. The colors of trucks, delivered may differ slightly from those in brochures.

The World of Hangcha



HANGCHA

A2 Series Internal Combustion Forklift

The A2 series is a series of forklifts of Hangcha based on the advanced technology through comprehensive upgrading of the exterior design, green and energy efficiency, safety and reliability, comfort and convenience. The forklifts have greatly improved performance, capable of meeting your all-round needs.



New design

- / Inherit the exterior design of Hangcha's A products and integrate innovation in classic style, thus the vehicle has a smooth vivid profile and a sturdy design.
- / The newly designed semi-enclosed instrument console make the entire forklift look compact and stylish.

Safety and reliability

- / The vehicle has an optimized layout design, reduced front overhang, lowered center of gravity and improved stability of the entire forklift.
- / The new channel steel, ultra-wide-view mast and lowered dashboard in the cab broaden the front view of the driver significantly.
- / Profiled steel overhead guard features high strength with good sealing of the cab.
- / The hydraulic system adopts 24° tapered seal to improve the sealing performance.
- / The key parts use water-proof plugs and connectors, improving the protection grade of the electric system and ensuring reliability of the entire forklift.



The newly developed steering axle assembly has a greatly prolonged service life through the optimization of the axle body, upgrading of the bearing, thickening of the cylinder and improvement to sealing.



The optimized heat dissipation system, improved counterweight heat dissipation channel and reduced wind resistance of the radiator enable the cooling efficiency to rise by 10%.



Ultra-wide-view mast and the front view of the driver broadened by 8%



The LED lighting system is provided in the entire forklift, which can save energy and power and greatly improve the performance and service life of lights.



The semi-enclosed instrument console make the entire forklift look compact and stylish.



Enlarged boarding step space allows more convenience for boarding.



The wide-open hood, increasing maintenance space by 10%

Comfort and convenience

- / Standard seat with an adjustable backrest has good packaging and anti-slip design, enabling a more comfortable driving and sitting experience.
- / The low-angle accelerator pedal reduces the driver's fatigue.
- / Integrated light combination switch makes the operation more convenient.
- / Integrated hydraulic cap allows for easier inspection and maintenance.



Large-screen LED instrument newly developed, which can completely display information such as the running status of the vehicle, fault detection and maintenance reminder in front of the driver more intuitively and can improve the convenience of maintenance.



With an optimized independent air intake channel and a large-capacity air intake silencer, the noise of the entire forklift is reduced by 2dB.

Optional attachments

- / Paper roll clamp
- / Rotatable roll clamp
- / Load stabilizer
- / Multi-purpose barrel clamp
- / Tie rod
- / Side shift fork
- / Rotating fork
- / Lengthened fork sleeve
- / Load ejector
- / Hook
- / Weighing system
- / Soft package clamp
- / Oil barrel clamp
- / Tipping fork
- / Boom
- / Lengthened fork
- / Cardboard box clamp
- / Push-puller
- / Bucket

Mast's special device

- / Free duplex wide-view mast
- / Special fork
- / Free triplex wide-view mast
- / Heightened load backrest
- / Special duplex wide-view mast
- / Widened fork carriage

Standard Specification

- / Protective boarding step
- / Air filter
- / Hydraulic oil dipstick
- / Traction device
- / Flow control valve
- / Fully hydraulic power steering
- / Duplex ultra-wide-view mast
- / Standard fork
- / Lifting and tilting joystick
- / Steering wheel adjusting device
- / Large rubber pedal pad
- / Left boarding handle
- / Large-screen LED instrument
- / Half package type instrument cover
- / Oil gauge
- / Pre-heating prompt
- / Engine oil pressure alarm
- / Neutral gear safety switch
- / Seat with an adjustable backrest and safety belt
- / Profiled overhead guard
- / Gearbox dipstick (hydraulic transmission)
- / Tires special for Hangcha
- / Load backrest
- / High-position air intake device
- / Hydraulic oil suction filter cartridge
- / Self-locking valve in the tilting fuel circuit
- / Cable-type stop brake
- / Light combination switch
- / Head lamp protective frame
- / Reverse buzzer
- / Class II (III) fork carriage
- / Engine hour counter
- / Load safety valve
- / Air spring with fuse
- / Charge prompt
- / Oil cooler (hydraulic transmission)
- / Vehicle toolkit
- / Water temperature meter

- / Two-piece multiway valve
- / Air intake silencer
- / 24° conic hydraulic line
- / Oil-water separator
- / Electric fuel pump
- / Engine failure prompt
- / Rearview mirror
- / Folder
- / Integrated electrical box
- / Electric flameout
- / Cup holder
- / Front LED operating light
- / LED front light and rear combination indicator
- / Electric horn
- / Rainproof cover
- / Electronic accelerator pedal
- / Gearbox oil temperature alarm (hydraulic transmission)

Options

- / Tilt cylinder jacket
- / Dual front wheel
- / Cab
- / High-position exhauster
- / User specified color
- / Cab heater
- / Fully-suspended seat
- / Tire chamber seal plate
- / Rear LED operating light
- / Heat dissipater grille
- / Solid tire
- / No mark solid tire
- / Mid-position emission device
- / Exhaust fire protection device
- / Water tank grille cover
- / Lockable hood
- / Electric steering
- / Fire extinguisher
- / Rear armrest with a horn button
- / Counterweight grille
- / High and low overhead guards
- / Alarm light
- / Speedometer
- / Velocimeter
- / Rear combination lamp protective frame
- / High-speed gearbox
- / Main power switch
- / Fan protection device
- / Overspeed alarm
- / Double air filters
- / Fuel tank cap locked
- / Double-layer soundproof hood padding and leather sheath





1.5-1.8t Mast Specification:(Pneumatic)

Type	Model	Max. fork height mm	Overall height			Free lift height		Front Overhang		Tilt range FWD/RWD (°)	Capacity Load Capacity at 500mm			
			Lowered mm	Extended		Without backrest mm	With backrest mm	1.5t mm	1.75t mm		Load Capacity at 500mm			
				Without backrest mm	With backrest mm						Single Tire		Double tire	
Wide view Duplex mast	A2A15/18M250	2500	1745	3048	3158	155	155	405	410	6/12	1500	1750	1500	1750
	A2A15/18M270	2700	1845	3248	3358	155	155	405	410	6/12	1500	1750	1500	1750
	A2A15/18M300	3000	1995	3548	3658	155	155	405	410	6/12	1500	1750	1500	1750
	A2A15/18M330	3300	2145	3848	3958	155	155	405	410	6/12	1500	1750	1500	1750
	A2A15/18M360	3600	2345	4148	4258	155	155	405	410	6/12	1500	1750	1500	1750
	A2A15/18M400	4000	2595	4548	4658	155	155	405	410	6/12	1500	1750	1500	1750
	A2A15/18M430	4300	2745	4848	4958	155	155	405	410	6/6	1350	1550	1400	1650
	A2A15/18M450	4500	2845	5048	5158	155	155	405	410	6/6	1300	1450	1350	1550
	A2A15/18M480	4800	2995	5348	5458	155	155	405	410	6/6	1200	1300	1250	1400
	A2A15/18M500	5000	3095	5548	5658	155	155	405	410	6/6	1150	1200	1200	1350
Free duplex wide-view mast	A2A15/18U250	2500	1760	3074	3184	1186	815	405	410	6/12	1500	1750	1500	1750
	A2A15/18U270	2700	1860	3274	3384	1286	915	405	410	6/12	1500	1750	1500	1750
	A2A15/18U300	3000	2010	3574	3684	1436	1065	405	410	6/12	1500	1750	1500	1750
	A2A15/18U330	3300	2160	3874	3984	1586	1215	405	410	6/12	1500	1750	1500	1750
	A2A15/18U360	3600	2310	4174	4284	1736	1365	405	410	6/12	1500	1750	1500	1750
Free triplex wide-view mast	A2A15/18N400	4000	2560	4574	4684	1986	1615	405	410	6/12	1500	1750	1500	1750
	A2A15/18N430	4300	2660	4874	4984	1486	1115	413	418	6/6	1300	1550	1400	1650
	A2A15/18N450	4500	2760	5174	5284	1586	1215	413	418	6/6	1250	1450	1350	1550
	A2A15/18N480	4800	2860	5474	5584	1686	1315	413	418	6/6	1200	1350	1300	1450
	A2A15/18N500	5000	2960	5774	5884	1786	1415	413	418	6/6	1150	1300	1200	1350
	A2A15/18N550	5500	3160	6174	6284	1986	1615	413	418	3/6	850	950	1050	1200
	A2A15/18N600	6000	3360	6574	6684	2186	1815	413	418	3/6	750	850	950	1050
	A2A15/18N650	6500	3560	6974	7084	2386	2015	413	418	3/6	/	/	650	750
	A2A15/18N700	7000	3760	7374	7484	2586	2215	413	418	3/6	/	/	450	550

With sideshifter minus 100kg, with integrated sideshifter minus 150kg.

2.0-2.5t Mast Specification:(Pneumatic)

Type	Model	Max. fork height mm	Overall height			Free lift height		Front Overhang mm	Tilt range FWD/RWD (°)	Capacity Load Capacity at 500mm			
			Lowered mm	Extended		Without backrest mm	With backrest mm			Load Capacity at 500mm			
				Without backrest mm	With backrest mm					Single Tire		Double tire	
Wide view Duplex mast	A2A25M250	2500	1749	3207	3546	160	160	460	6/12	2000	2500	2000	2500
	A2A25M270	2700	1849	3407	3746	160	160	460	6/12	2000	2500	2000	2500
	A2A25M300	3000	1999	3707	4045	160	160	460	6/12	2000	2500	2000	2500
	A2A25M330	3300	2149	4007	4346	160	160	460	6/12	2000	2500	2000	2500
	A2A25M360	3600	2349	4307	4646	160	160	460	6/12	2000	2500	2000	2500
	A2A25M400	4000	2599	4707	5046	160	160	460	6/12	2000	2500	2000	2500
	A2A25M430	4300	2749	5007	5346	160	160	460	6/6	1900	2300	2000	2500
	A2A25M450	4500	2849	5207	5546	160	160	460	6/6	1800	2200	1900	2400
	A2A25M480	4800	2999	5507	5846	160	160	460	6/6	1750	2100	1800	2300
	A2A25M500	5000	3099	5707	6046	160	160	460	6/6	1650	1800	1750	2250
Free duplex wide-view mast	A2A25M550	5500	3349	6207	6546	160	160	460	3/6	1400	1500	1700	2000
	A2A25M600	6000	3599	6707	7046	160	160	460	3/6	1000	1050	1600	1800
	A2A25U250	2500	1764	3179	3546	1025	718	470.5	6/12	2000	2500	2000	2500
	A2A25U270	2700	1864	3379	3746	1125	818	470.5	6/12	2000	2500	2000	2500
	A2A25U300	3000	2014	3679	4046	1275	968	470.5	6/12	2000	2500	2000	2500
Free triplex wide-view mast	A2A25U330	3300	2164	3979	4346	1425	1118	470.5	6/12	2000	2500	2000	2500
	A2A25U360	3600	2314	4279	4646	1575	1268	470.5	6/12	2000	2500	2000	2500
	A2A25U400	4000	2564	4679	5046	1825	1518	470.5	6/12	2000	2500	2000	2500
	A2A25N400	4000	1964	4676	5046	1285	918	477.5	6/6	2000	2500	2000	2500
	A2A25N430	4300	2064	4976	5346	1385	1018	477.5	6/6	1850	2300	1900	2400
	A2A25N450	4500	2114	5176	5546	1435	1068	477.5	6/6	1800	2200	1850	2350
	A2A25N480	4800	2264	5476	5846	1585	1218	477.5	6/6	1750	2000	1800	2300
	A2A25N500	5000	2364	5676	6046	1685	1318	477.5	6/6	1650	1800	1750	2250
	A2A25N550	5500	2564	6176	6546	1885	1518	477.5	3/6	1400	1500	1700	2150
	A2A25N600	6000	2814	6676	7046	2135	1768	477.5	3/6	1000	1050	1600	1800
Free triplex wide-view mast	A2A25N650	6500	3014	7176	7546	2335	1968	477.5	3/6	/	/	1300	1450
	A2A25N700	7000	3264	7764	8046	2500	2218	477.5	3/6	/	/	1200	1300

With sideshifter minus 100kg, with integrated sideshifter minus 150kg.

3.0-3.8t Mast Specification:(Pneumatic)

Type	Model	Max. fork height	Overall height						Free lift height						Tilt range		Capacity						
			Lowered		Extended				Without backrest		With backrest				Front Overhang		FWD/RWD	Load Capacity at 500mm					
			3.0t	3.5t/3.8t	Without backrest		With backrest		Without backrest		With backrest		3.0t	3.5t/3.8t	Single Tire			Double tire					
			mm	mm	mm	mm	mm	mm	mm	mm	mm	mm	mm	mm	(°)	kg	kg	kg	kg	kg	kg		
Wide view Duplex mast	A2A30/35M250	2500	1804	1919	3209	3284	3645	3645	165	170	165	170	475	480	6/12	3000	3500	3800	3000	3500	3800		
	A2A30/35M270	2700	1904	2019	3409	3484	3845	3845	165	170	165	170	475	480	6/12	3000	3500	3800	3000	3500	3800		
	A2A30/35M300	3000	2054	2169	3709	3784	4140	4140	165	170	165	170	475	480	6/12	3000	3500	3800	3000	3500	3800		
	A2A30/35M330	3300	2204	2319	4009	4084	4445	4445	165	170	165	170	475	480	6/12	3000	3500	3800	3000	3500	3800		
	A2A30/35M360	3600	2404	2469	4309	4384	4745	4745	165	170	165	170	475	480	6/12	3000	3500	3800	3000	3500	3800		
	A2A30/35M400	4000	2654	2769	4709	4784	5145	5145	165	170	165	170	475	480	6/12	3000	3500	3800	3000	3500	3800		
	A2A30/35M430	4300	2804	2919	5009	5084	5445	5445	165	170	165	170	475	480	6/6	2900	3250	3650	3000	3400	3800		
	A2A30/35M450	4500	2904	3019	5209	5284	5645	5645	165	170	165	170	475	480	6/6	2850	3100	3350	3000	3350	3700		
	A2A30/35M480	4800	3054	3169	5509	5584	5945	5945	165	170	165	170	475	480	6/6	2700	2900	3000	2900	3000	3300		
	A2A30/35M500	5000	3154	3269	5709	5784	6145	6145	165	170	165	170	475	480	6/6	2550	2800	2850	2850	2900	3200		
	A2A30/35M550	5500	3404	3519	6209	6284	6645	6645	165	170	165	170	475	480	3/6	2250	2350	2400	2650	2700	3000		
	A2A30/35M600	6000	3654	3769	6709	6784	7145	7145	165	170	165	170	475	480	3/6	1550	1750	1800	2200	2300	2800		
Free duplex wide-view mast	A2A30/35U250	2500	1834	1934	3256	3331	3645	3645	1078	1103	689	789	485.5	490.5	6/12	3000	3500	3800	3000	3500	3800		
	A2A30/35U270	2700	1934	2034	3456	3531	3845	3845	1178	1203	789	889	485.5	490.5	6/12	3000	3500	3800	3000	3500	3800		
	A2A30/35U300	3000	2084	2184	3756	3831	4145	4145	1328	1353	939	1039	485.5	490.5	6/12	3000	3500	3800	3000	3500	3800		
	A2A30/35U330	3300	2234	2334	4056	4131	4445	4445	1478	1503	1089	1189	485.5	490.5	6/12	3000	3500	3800	3000	3500	3800		
	A2A30/35U360	3600	2384	2484	4356	4431	4745	4745	1628	1653	1239	1339	485.5	490.5	6/12	3000	3500	3800	3000	3500	3800		
	A2A30/35U400	4000	2634	2734	4756	4831	5145	5145	1878	1903	1489	1589	485.5	490.5	6/12	3000	3500	3800	3000	3500	3800		
Free triplex wide-view mast	A2A30/35N400	4000	2019	2119	4756	4831	5145	5145	1263	1288	874	974	492.5	497.5	6/6	3000	3500	3800	3000	3500	3800		
	A2A30/35N430	4300	2119	2219	5056	5131	5445	5445	1363	1388	974	1074	492.5	497.5	6/6	2900	3150	3300	2950	3350	3700		
	A2A30/35N450	4500	2169	2319	5256	5331	5645	5645	1413	1488	1024	1174	492.5	497.5	6/6	2800	3000	3250	2900	3200	3600		
	A2A30/35N480	4800	2319	2469	5556	5669	5945	5945	1563	1600	1174	1324	492.5	497.5	6/6	2700	2800	3000	2800	3000	3300		
	A2A30/35N500	5000	2419	2619	5756	5831	6145	6145	1663	1788	1274	1474	492.5	497.5	6/6	2550	2700	2800	2750	2850	3200		
	A2A30/35N550	5500	2619	2869	6256	6369	6645	6645	1863	2000	1474	1724	492.5	497.5	3/6	2250	2350	2400	2650	2700	2850		
	A2A30/35N600	6000	2869	3119	6756	6919	7145	7145	2113	2200	1724	1974	492.5	497.5	3/6	1550	1750	1800	2200	2300	2600		
	A2A30/35N650	6500	3119	3369	7256	7369	7645	7645	2363	2500	1974	2224	492.5	497.5	3/6	/	/	/	1950	2050	2300		
	A2A30/35N700	7000	3369	3619	7756	7919	8145	8145	2613	2700	2224	2474	492.5	497.5	3/6	/	/	/	1800	1900	2050		

With sideshifter minus 200kg, with integrated sideshifter minus 100kg.
Lift height 7.5m/8.0m is optional for front dual tyres.

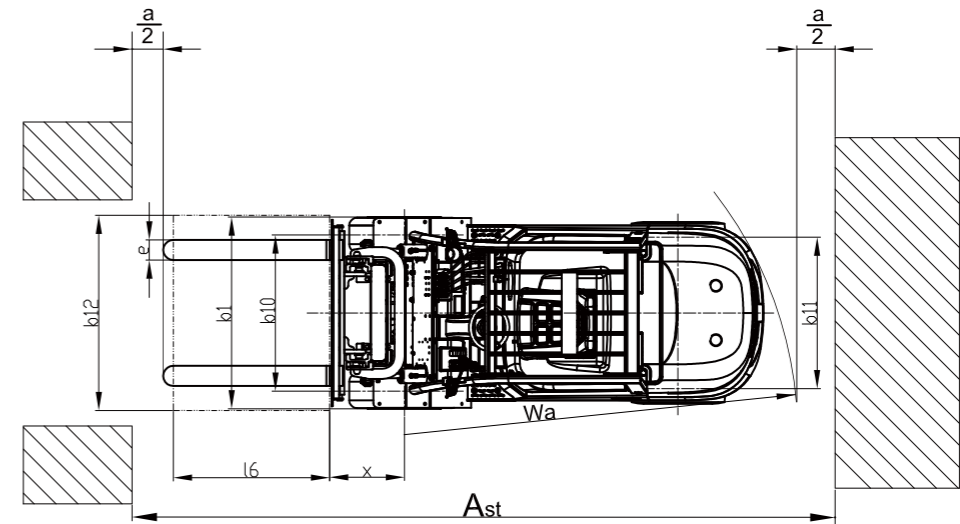
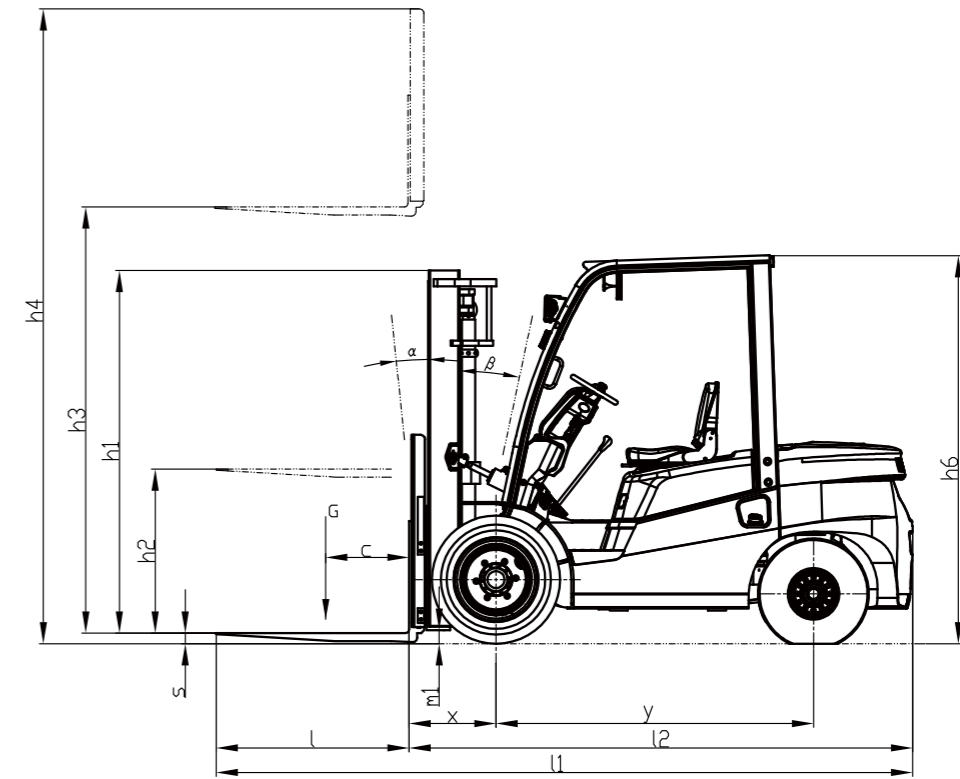

$$A_{st} = l_6 + x + W_a + a \quad L_6: \text{load length} \quad a: \text{Clearance (200mm)}$$

Capacity(kg)

